

*Any Way You Want  
to Slice It, a* **RYAN** *is Always Best*  
Technology, Inc.

## Product Specification Sheet

### Ryan Model 797 Rotary Table In-Feed Unit



# Ryan Model 797 Rotary Table In-Feed Unit

Rotary table unit to direct product into a single-line.

Capacity: Up to 8000 units per hour depending on product and in-feed method.

Will handle product up to 6" in width, 3" tall, and 24" long.

## Standard Features:

4 foot diameter rotary table  
6" wide conveyor with Intralox friction top chain  
Stainless steel tubular frame  
3-Phase power 15 amp  
Adjustable rigid feet

## Options:

Turn table/conveyor variable speed drive  
In-feed conveyor up to 40" wide, level or in-  
clined  
In-table in-feed product guide (for sub-roll-type  
products)  
Right-hand or left-hand configuration (left-hand  
shown)  
Wash down upgrade available

[ Shown below feeding a Model 892 Slicer]

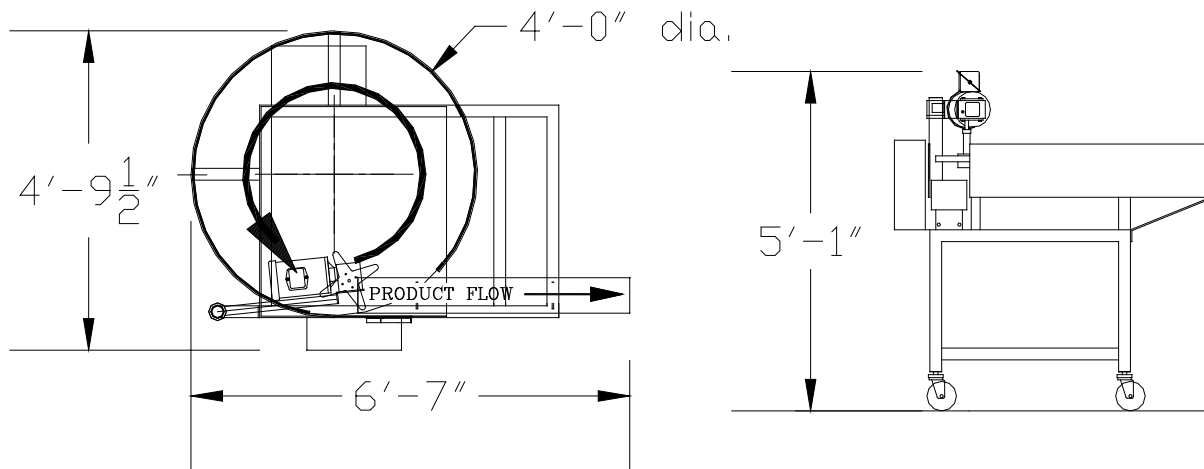

**RYAN**  
TECHNOLOGY, INC.

©8/2019

1-800-277-2290 • 503-648-9967 • 503-640-3846 (Fax) • [www.RyanSlicer.com](http://www.RyanSlicer.com)

P.O. Box 1960 Hillsboro, OR 97123-1960 USA