

*Any Way You Want
to Slice It, a*

RYAN
Technology, Inc.

is Always Best

Product Specification Sheet

Ryan Model 1097 Rotary Table Utility Slicer



Ryan Model 1097 Rotary Table Utility Slicer

High-speed versatile horizontal slicer for French rolls, bagels, English muffins, buns, croissants, etc.

Capacity: Up to 8000 units per hour depending on product and in-feed method.

Will handle product up to 8" in width, 3" tall, and 24" long.

Single-blade (1097A) or Dual-blade (1097B) Configuration

Standard Features:

4 foot diameter rotary table

8" wide conveyor

USDA approved powder-coated tubular steel frame

Plated steel blade housings, conveyors, and guards

1 HP motors on blades with brakes to stop blades within one revolution upon shut-down

Coded magnetic safety switches on lexan blade covers that allow operation only when covers are in place

14" circular saw blades

Adjustable for cut height, depth, and product width

Factory adjustable conveyor speed (non-vary-drive machines)

3-Phase power (208 or 240 volt) 15 amp

5" casters

Options:

Ryton coating on blades

Turn table/conveyor variable speed drive

In-table in-feed product guide (for sub-roll-type products)

Right-hand or left-hand configuration (left-hand shown)

Wash down upgrade

Crate Size: (1097B) 78.5" x 68" x 56" H

©9/2016

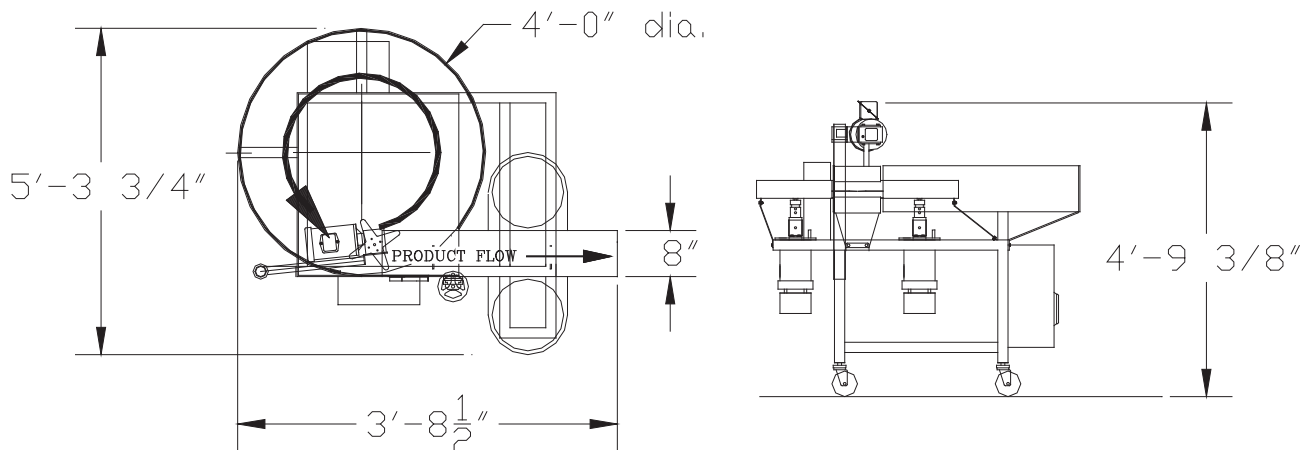

RYAN
TECHNOLOGY, INC.

1-800-277-2290 • 503-648-9967 • 503-640-3846 (Fax) • www.RyanSlicer.com

P.O. Box 1960 Hillsboro, OR 97123-1960 USA