

Ryan Model 904 Rotary Table Sub Roll Slicer

*Right-hand unit shown without in-feed conveyor.

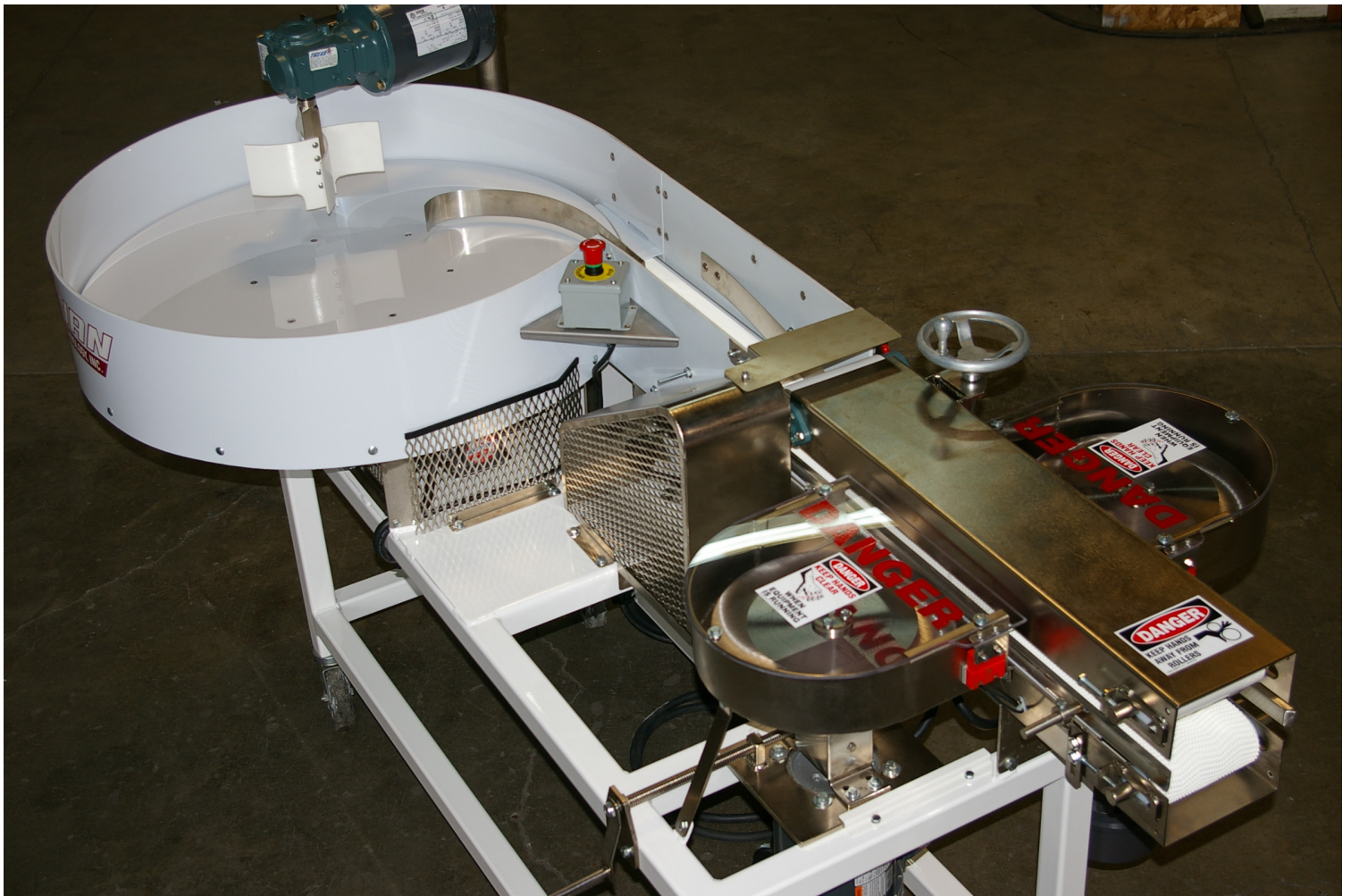

RYAN
TECHNOLOGY, INC.

Ryan Model 904 Rotary Sub Roll Slicer with In-feed Conveyor

High-speed versatile horizontal slicer for sub rolls, bagels, English muffins, buns, croissants, etc.

Capacity: Up to 8000 units per hour depending on product and in-feed method.

Will handle product up to 7 ½" in width, 3" tall, and 12" long.

Single-blade (904A) or Dual-blade (904B) Configuration

Standard Features:

3 foot diameter rotary table

7" main conveyor and 24" wide in-feed conveyor (photo on opposite page without in-feed)

23" space between table and upper conveyor capture

USDA approved powder-coated tubular steel frame

Plated steel blade housings, conveyors, and guards

1 HP motors on blades with brakes to stop blades within one revolution upon shut-down

Coded magnetic safety switches on Lexan blade covers that allow operation only when covers are in place

12" circular saw blades

Adjustable for cut height, depth, and product width

Turn table & conveyor variable speed drives

3-Phase power (208 or 240 volt) 20 amp

5" casters

Options:

Ryton coating on blades

Right-hand or left-hand configuration (left-hand shown below, photo right-hand w/o in-feed)

©9/2016

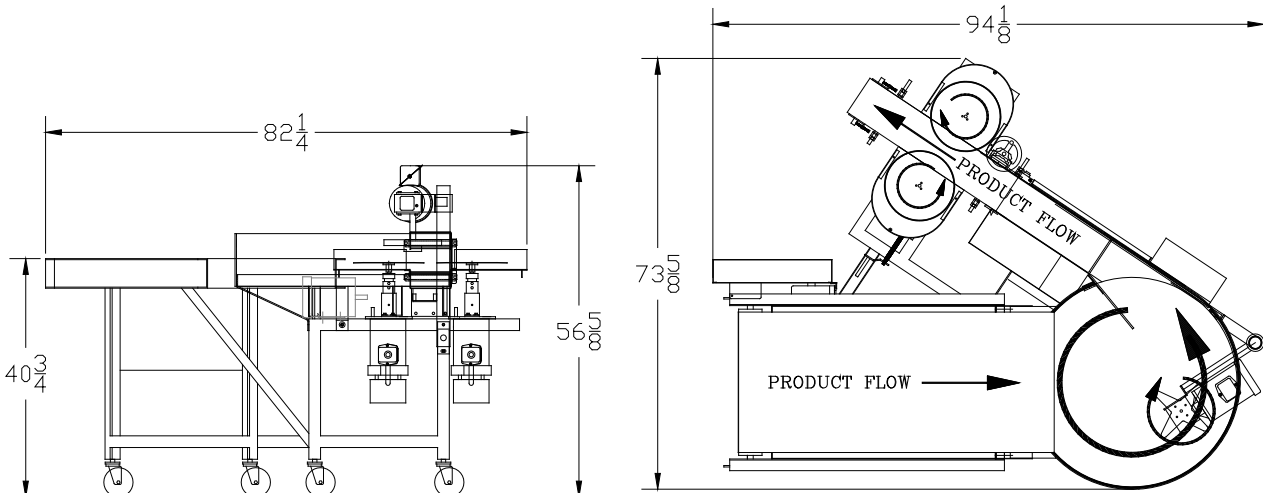

RYAN
TECHNOLOGY, INC.